

Code:

# CAA10

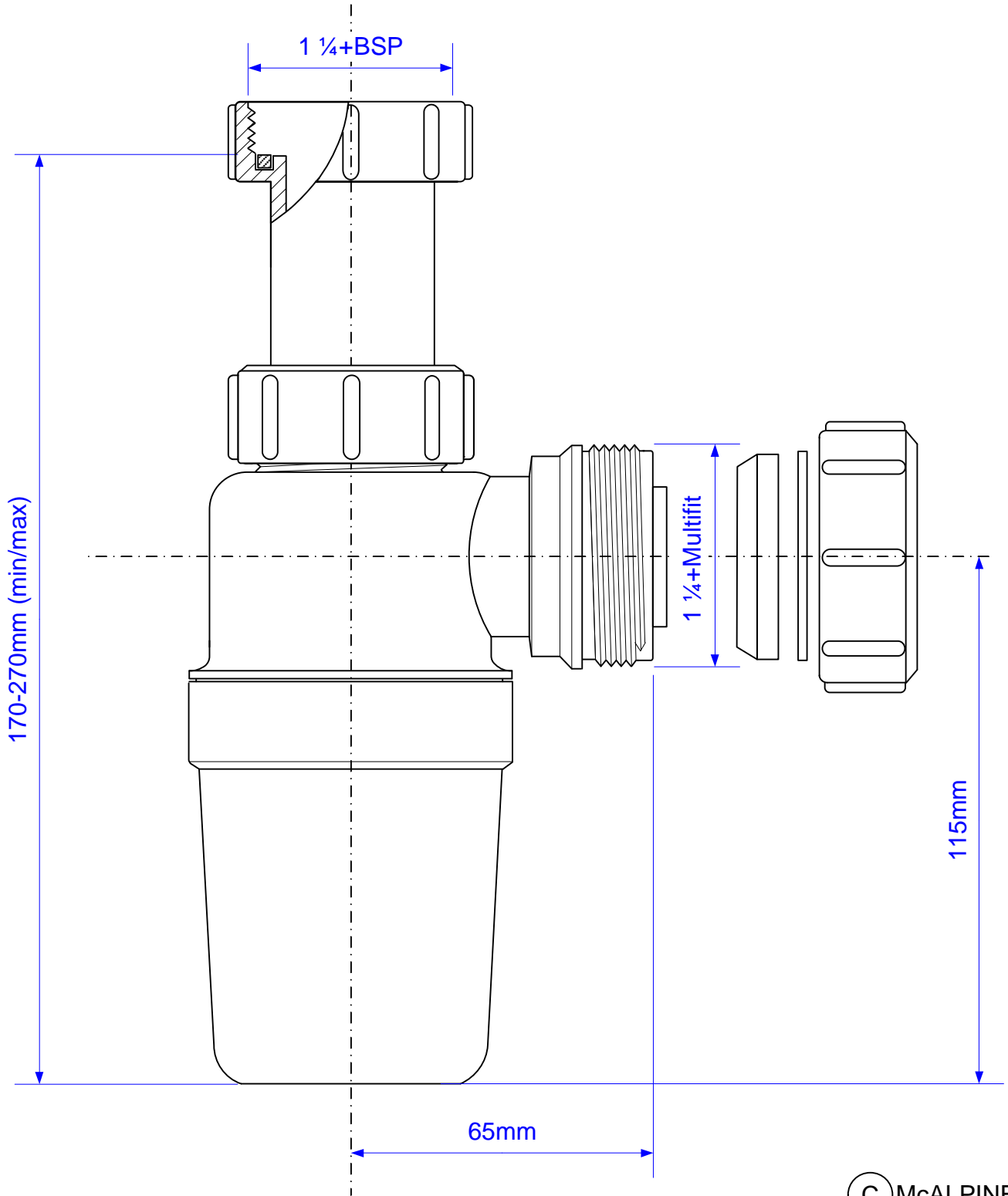

© McALPINE  
29/05/2004

Drawing verified  
correct as of:

29/05/2004

DRAWN BY

RM

REVISED

1-Amend height TC 21.01.19  
2-Add pg2 (TC 29.05.19)

FILENAME

CAA10.VSDX

SCALE

1: 1.25

DATE

29/05/2004

Code:

# CAA10

No.	Qty	Code	Material
1	1	32M	EPDM
2	1	STALK-1/P-32CP	Chrome Plated ABS
3	1	S8B-CP	Chrome Plated ABS
4	1	AA10-TUBE-NEW	TPE
5	1	AA10TOPNEW-CP	Chrome Plated ABS
6	1	P-OR-A10R	Nitrile
7	1	AA10BOTTNEW-CP	Chrome Plated ABS
8	1	RWM1	TPE
9	1	PWM1	Polypropylene
10	1	S8M-CP	Chrome Plated ABS

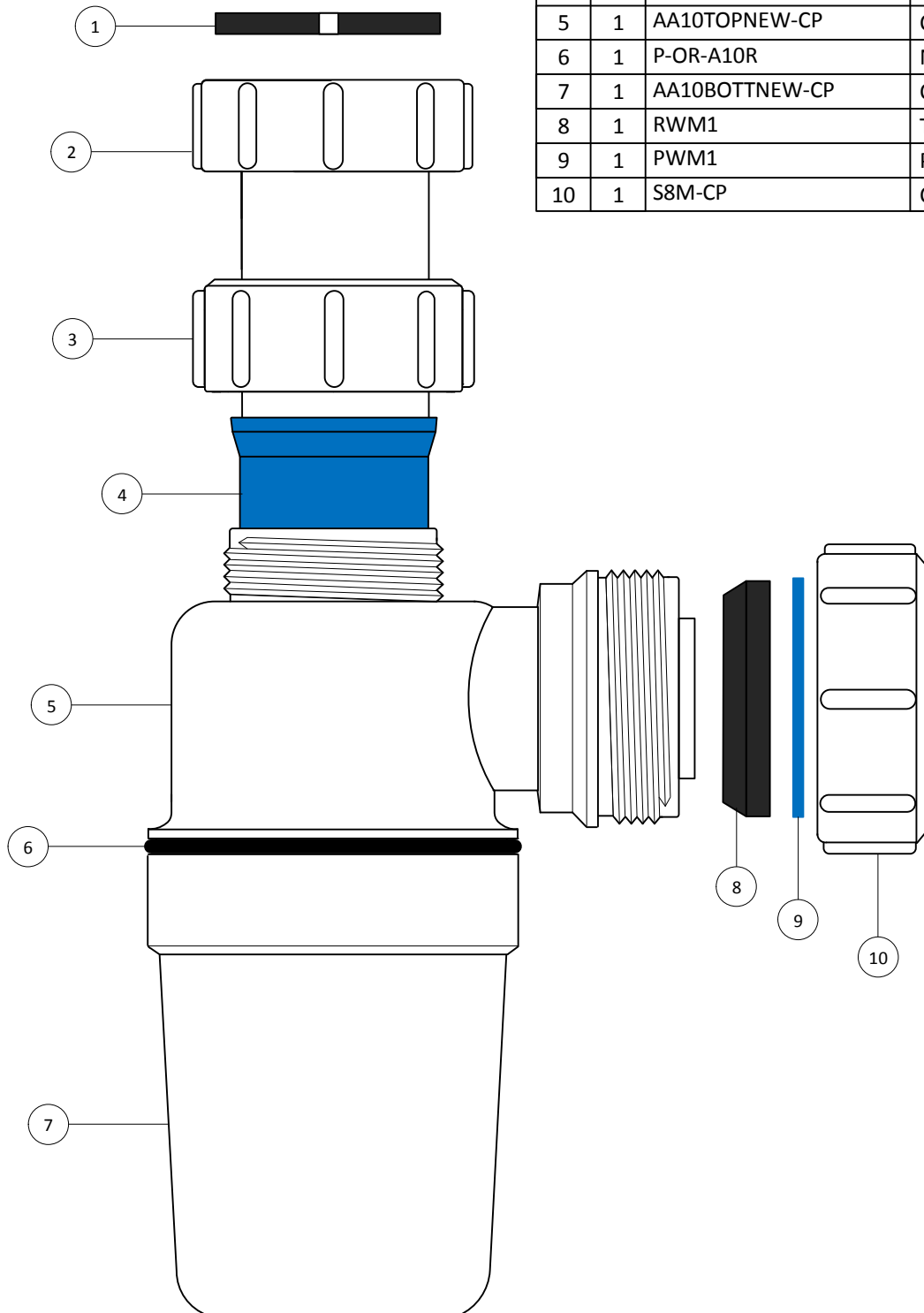

© McALPINE  
29/05/2004

Drawing verified  
correct as of:

29/05/2004

DRAWN BY

RM

REVISED

1-Amend height TC 21.01.19  
2-Add pg2 (TC 29.05.19)

FILENAME

CAA10.VSDX

SCALE

1: 1.25

DATE

29/05/2004